

**30 Years**  
Inner Excellence

## MA30 The Mundorf Anniversary Kit

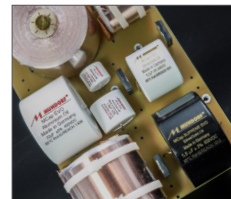
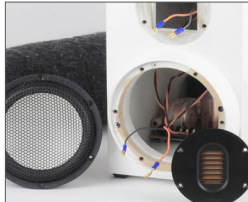

*For our 30 Year Company Anniversary  
Incorporating some of our best Xover components and our AMT  
tweeter. Up to MA50 in some twenty years from now, a truly unique kit!*

 **MUNDORF®**

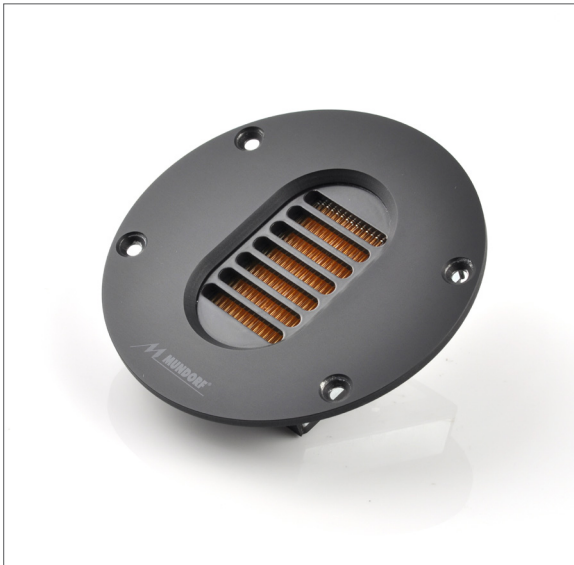

AMT19CM1.1 • Pneumatic Air Motion Tweeter



ACCUTON C158-8-085 • Ceramic Mid-Woofer

### MA30 Anniversary Series FE

MA30 Anniversary Kit contains:  
2 AMT19CM1.1 tweeters  
2 ACCUTON C158-8-085  
Ceramic Mid-Woofers  
2 finished Xovers assembled with  
2 MCap SUP EVO Alu.Oil  
2 MCap EVO Oil  
6 MCap EVO  
8 PBH Resistors  
6 MCoil Copper Foil Inductors  
+ Cabinet Blueprint

Frequency Range: 48Hz-30kHz  
Crossover: 3450Hz/6dB/1st. order  
Sensitivity: 86 dB/1W/1 m  
Max. SPL: 103 dB  
Impedance: 8 Ohm  
Recom. Amplifier: >100W/channel

Kit price: €1459 (Final Edt. 2017)

### MA30 SilverGold SG Series FE

MA30 SilverGold Kit contains:  
2 AMT19CM1.1 tweeters  
2 ACCUTON C158-8-085  
Ceramic Mid-Woofers  
2 finished Xovers assembled with  
2 MCap SUP EVO SG.Oil  
2 MCap EVO SG.Oil  
6 MCap EVO Oil  
8 PBH Resistors  
6 MCoil Copper Foil Inductors  
+ Angel Hair (Damping Wool)  
+ Cabinet Blueprint

Frequency Range: 48Hz-30kHz  
Crossover: 3450Hz/6dB/1st. order  
Sensitivity: 86 dB/1W/1 m  
Max. SPL: 103 dB  
Impedance: 8 Ohm  
Recom. Amplifier: >100W/channel

Kit price: €1639 (Final Edt. 2017)



Anniversery Series X-Over with SUP EVO Alu.Oil

### Why this kit ensemble in particular?

Why a combo of the most less expensive Mundorf AMT tweeter and the most less expensive Accuton Ceramic Mid-Woofer? Simply because of the beforehand defined task, which was not easy to achieve: To offer a Hi-End Speaker Kit as affordable as any possible but, same time, clearly outperforming all competing kits by being at least one level superior. A kit which of both Mundorf and Accuton company would be proud of! And, finally, a kit that everybody can easily assemble into an easy-to-build but thoughtfully designed cabinet. Nicely designed and accurately engineered to the Ceramic woofer's particulars and properties.



SG Series X-Over with SUP EVO SG.Oil

### Xover in true anniversery quality

The crossover layout is purely serial, thus there are no parallel components in the entire crossover. Also, the layout is done for bi-wiring resp. bi-amping. Crossover frequency is 3450Hz. High-pass and low-pass are 1st. order/6dB filters, designed as a Notch-Filter in both high-pass and low-pass filters. A Notch-Filter is basically a band-pass filter in series wiring, which, amongst others, helps to eliminate peaks in the frequency response of a loudspeaker, hence, it is for linearization purpose.

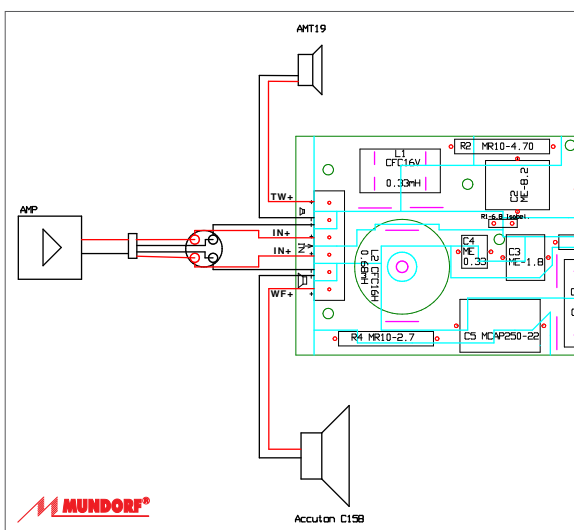

Bi-Wiring/-Amping • MA30 Kit Xover-Layout

30 Years Mundorf Anniversery Kit • Entirely Made in Germany



Woofer installed 18 mm forward

### 18mm difference for harmony!

The accurate cabinet volume for the MA 30 kit is 11.5 litres (0.5 l for the crossover network). A cabinet blueprint is included in the scope of delivery. When arranging the cabinet, care should be taken to ensure that the vertical installation difference of 18 mm is adhered to for correct response time correction, so either the woofer/midrange speaker is installed in front or the AMT tweeter is installed in reverse.

### Speaker cabinets for the MA30 Kit?

Ready-made or kit cabinets for the MA30 Kit are not available from Mundorf. The cabinets shown in brochures, audio magazines and at exhibitions were produced by well-known cabinet manufacturers in Asia in accordance with our blueprint for our local and international kit distributors and, based on an individual service agreement, were also delivered fully assembled as factory assembled kits.

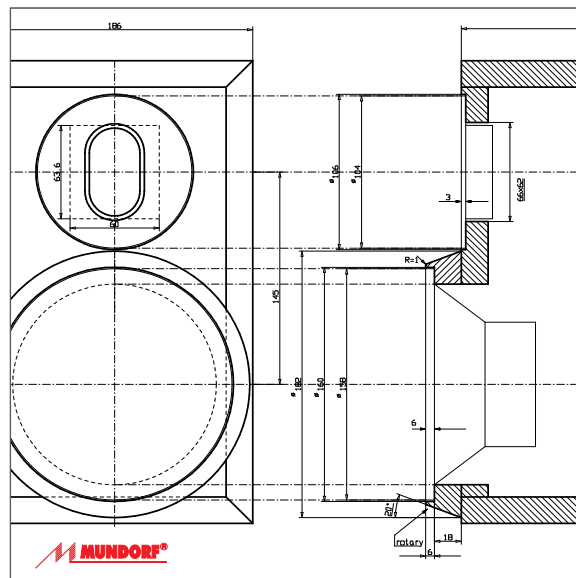

MA30 kit cabinet blueprint extract

### Who realised the MA30 concept?

Electrically and physically, company Thiel & Partner resp. Accuton's engineers were fundamentally responsible. They are utterly accustomed to match their drivers with Mundorf Xover parts because they are Accuton's OEM development parts ever since. More importantly, these engineers really know their drivers inside out and better than anybody else in terms of the driver's given pros and cons. Hence, the Accuton people are the most skilled match-makers when it comes to Accuton Ceramic drivers and our building parts. However, the final musical tuning was ultimately determined by Mundorf engineers and employees in numerous joint listening sessions.

### Individual completion

Mundorf deliberately did not create a fully equipped kit for to leave as much room for personal preferences as possible. Your MA30 dealer will assist you on that individually.



Mundorf AMT19CM1.1 • front view

## AMT19CM1.1

RESISTANCE	NOMINAL 8 OHM	
Zo 8.4 OHM	• Zmin 8.2 OHM	• RE 8.1 OHM
SENSITIVITY @ 2.83 V	91 dB	
FREQUENCY RESPONSE / -6 dB	2000 Hz – 35 kHz	
POWER HANDLING	120 W	
RESONANCE FREQUENCY / FS	2300 Hz	
RECOMMENDED CROSSOVER / 6 dB	3100 Hz	
RECOMMENDED CROSSOVER / 12 dB	2800 Hz	
DISPERSION HORIZONTAL / 15 kHz / -6 dB	65°	
DIAPHRAGM AREA	1260 mm <sup>2</sup>	
MAGNET MATERIAL	NEODYMIUM	
FACE PLATE	3 mm Anodized Aluminum	
TOTAL WEIGHT	340 g	
FACE PLATE DIAM.	104 mm	

AMT19CM1.1 specs and measurements

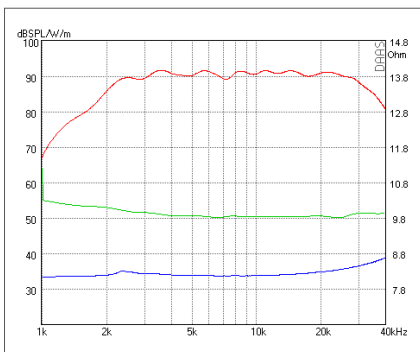

SPL 2.83 V - Phase - Impedance

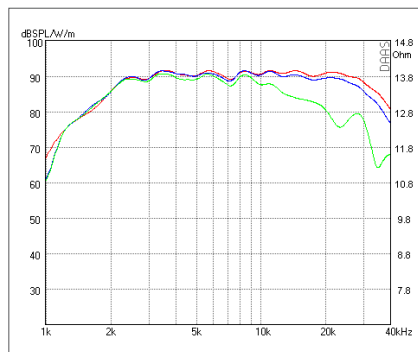

SPL Horizontally 0° - 15° - 30°

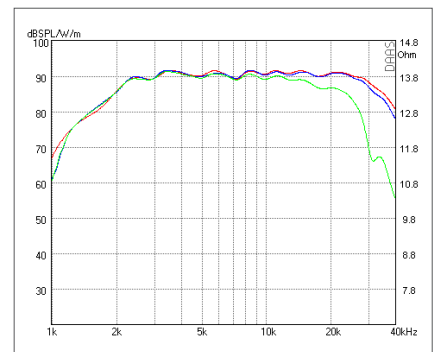

SPL Vertically 0° - 5° - 15°

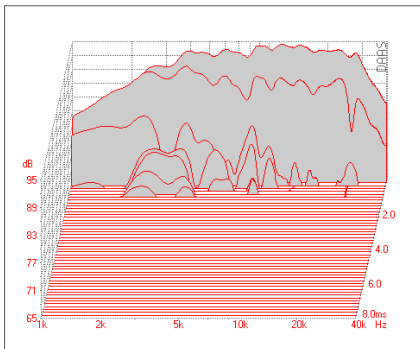

Waterfall



Mundorf AMT19CM1.1 • rear view

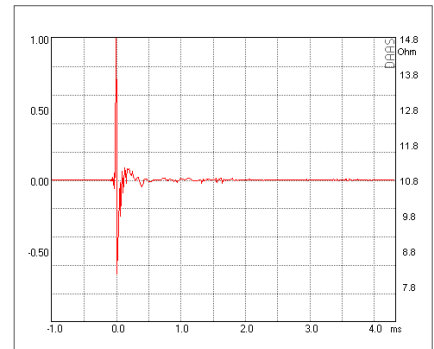

Impulse Response

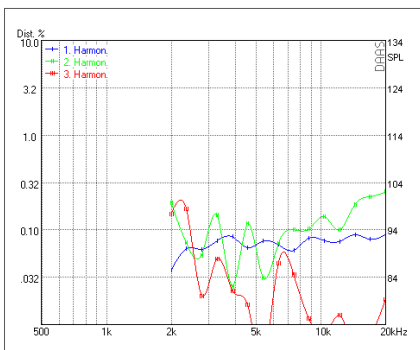

Harmonic Distortion 2.83 V

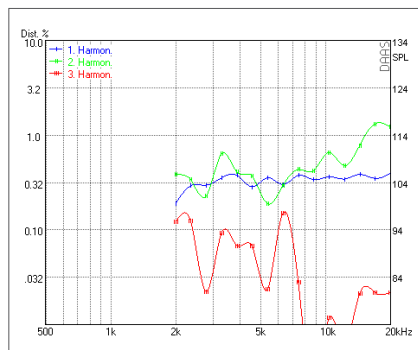

Harmonic Distortion 105 dB

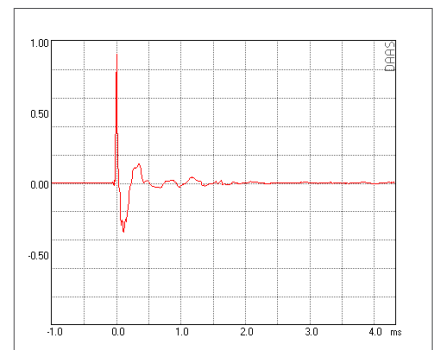

Step Response

## MA30 Set-Up

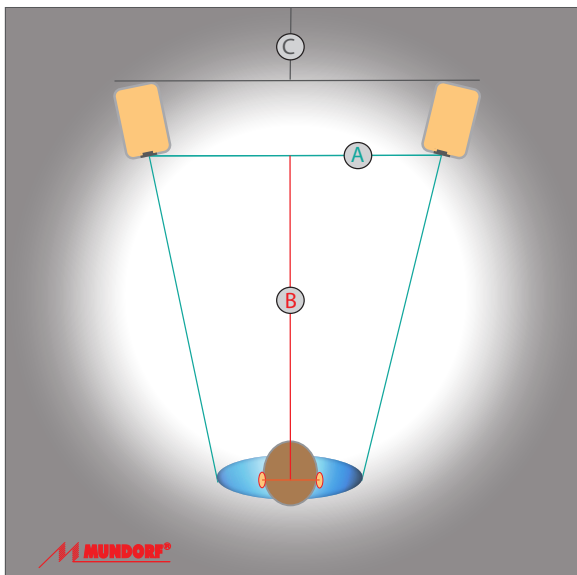

A 6,6ft to 8,2ft • B 6.6ft to 9,8ft • C 1,3ft to 2,0ft

To fully enjoy every aspect of those kits' extraordinary music performance, there are 3 essential basic rules we strongly recommend to follow. In return, your MA30 Kit will reward you with its a surprisingly solid, deep and resonance-free bass and with its outstandingly precise defined 3D-sound-stage!

Firstly, both AMT tweeters should exactly point towards the listener's shoulder joint when sitting in the "Sweet Spot".

Secondly, the virtual horizontal line between AMT tweeter and Ceramic woofer should correspond to the listener's ear level.

Thirdly, don't place MA30 closer than 45cm/16" or more than 60cm/24" distant from the room's rear wall (side distance isn't similarly crucial but, for avoiding the risk of low frequent roomresonances, MA30's distance to side walls shouldn't be less than about 30cm/12").

The actual set-up in terms of distance between the speakers and their distance to the "Sweet Spot" can be arranged according to the room acoustic and the listener's individual listening habits.

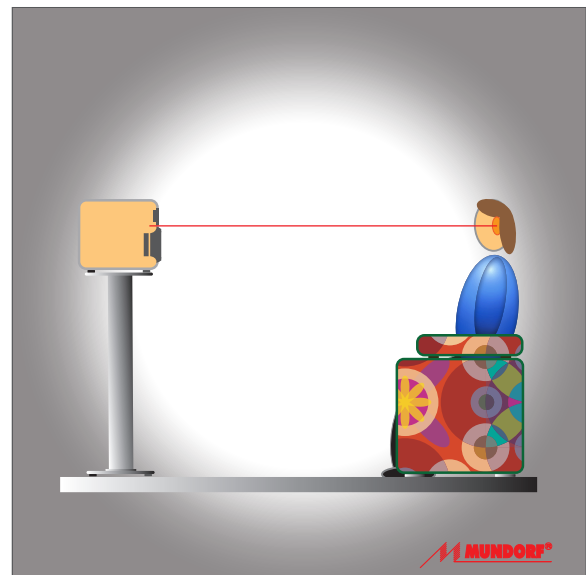

Ear-level: The • between tweeter and woofer

Generally, the distance between the speakers should be a little less than their distance to the "Sweet Spot". However, thanks to its accurately tuned frequency range MA30 Kit fits technically perfectly well into the vast variety of today's listening and living rooms - be they large or small.



MA30 Set-Up

30 Years Mundorf Anniversary Kit • Entirely Made in Germany

# MA30 On Music



The Mundorf MA30 Anniversary Kit sounds every bit as good as one would expect from the collaboration between two manufacturers who produce the highest quality electronic components and loudspeakers for the audiophile masterpieces of world-class Hi-End manufacturers: Enthrallingly beautiful and true to life! And vice versa. And with any kind of music.

One of the reasons, for sure, is the high quality drivers built into it. But the key ingredient is unquestionably its sophisticated 6 dB crossover with notch filters, made with the best Mundorf crossover components for to guarantee a very neutral tonal matching of the speaker kit. Ultimately, it is the music which should bare its character and its soul, not the speakers.

Finally, the time-aligning speaker enclosure puts the final touches on the listening pleasure. Once the setup recommendations in this brochure are followed then, when playing correct recordings, the speakers “disappear”, and are not perceived as the source of the music. Freed from its enclosures, the music spreads to fill the listening space, wide, high and deep, forming a holograph in the room, with precisely positioned and contoured instruments and voices. It is just wonderful, to hear, for example, Madeleine Peyroux performing “Dance Me To The End Of Love”: She stands not on a stage, but on a platform like you’d find in a typical hotel bar. Piano, harmonica, drums and bass are arranged from left to right in a half circle in the background, while Madeleine stands in the very centre in front of the combo. From where the audience listens, the instruments and Madeleine all materialize as a complete scene, with every player in place (never straying). While the combo provides a soft background of finely swinging groove, there’s no mistaking to whom Madeleine’s amorous advances are directed: The bewitched listener. Beguilingly beautiful and sexy.

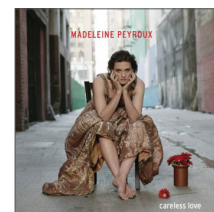

For another very beautiful experience that will please jazz lovers and long-time audiophiles, take yourself back to the famous “Pawnshop” and rediscover the “Limehouse Blues”: The MA30 Kit is convincingly life-like and emotionally stirring as the band strikes up. A few sounds from the prelude, and as a listener you are right in the jazz club mood. The wealth of detail and the fine dynamics, the metronomically precise rhythms, the radiant transparency, the well balanced tempering and the ever-present, lively swing of the music are all there, mostly thanks to the extremely ‘fast-response’ of the Air Motion Transformer (AMT) and its extraordinarily low distortion ratio due to its principle.



Whereas the stable foundation, force and surprisingly high pulse strength and definition in the low range and the finely nuanced tonal colours of the mids are testimony to the quality of the mid-woofer. This can be physically experienced with every kind of “Yello-alike” music. In contrast to this, there is the bass on a blissful album like “Jaco” by jazz musician Brian Bromberg, which positively “sings” out those deep tones in the musical tradition of bassist extraordinaire Jaco Pastorius, who lamentably left this world too soon.

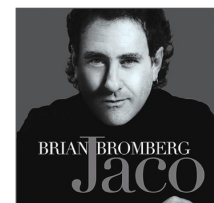

So, is there anything the MA30 Kit can’t do? There is: A full line-up of Carl Orff’s “Carmina Burana” at live volume. But, let’s face it, this and similar gargantuan music will only ever fit in a full-size concert hall.

It is natural that Xover and our AMT (Air Motion Transformer) form the core of the kit. After all, we are celebrating our 30 Year Anniversary as a manufacturer of crossover components and AMT tweeters. We are confident that we have indeed come very close to the stated objective of making the results of the anniversary kit sound “a price range higher” with a well-thought-out combination of good, cost-effective speakers and choice top crossover network components.

We are more than delighted to offer MA30’s “one price range nicer performance” as an anniversary bonus for many hours of happy listening to all those music lovers who want not only to listen to music in excellent quality but also to experience music in terms of an emotional event. At the bottom line, that is what music is all about.

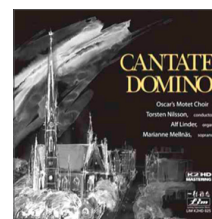

# MA30 Kit *Int'l*

Since April 2015, the kit has been presented at 18 international audio shows in Asia, North America and Europe



MA30 Kit at CAS, San Francisco, USA 2015



MA30 Kit at RMAF, Denver, USA 2015



MA30 Kit at TAVES, Toronto, Canada 2015



MA30 Kit at Munich Hi-End Show, Germany 2016



MA30 Kit at Guangzhou AV Show, China 2016



MA30 Kit at SIAV, Shanghai, China 2017



© 2015 - 2017  
MUNDORF EB GMBH  
info@mundorf.com  
mundorf.com